

GENERAL INFORMATION ON GLASS

SAFETY GLASS

STANDARD
SUN-PROTECTIVE
THERMAL INSULATING
SOUND-PROOFING
SAFETY
GLASSPLATE®

GLASS CUT FOR MEASURE

DECORATIVE
SAFETY
REFLEXION
MIRRORS

POSSIBILITY OF THE GLASS PROCESSING

DRILLING
FACETTING
BENDING
GRINDING
HARDENING
POLISHING
CUTTING
SAND BLASTING
LAMINATING
GLASS WITH PRINTS
CEMENTING OF AQUARIA AND TERRARIA



**SKLENÁŘSTVÍ
NONSTOP**

Quality management system ISO 9001:2001
has been introduced by the company

CONFIDENTIALITY OF INFORMATION

**This document contains information of confidential character.
It is destined for authorised persons exclusively.
It can not be quoted, copied or passed over to a third physical
or artificial person without a previous approval.**

CONTENT

<u>HISTORY OF GLASS</u>	4 – 5
<u>COMPANY'S BASIC INFORMATION</u>	6
<u>GENERAL INFORMATION</u>	7 – 8
<u>TERMS OF AN ORDER</u>	9
<u>TECHNICAL DESCRIPTION OF SAFETY GLASS</u>	10
<u>TECHNICAL PARAMETERS OF SAFETY GLASS</u>	11
<u>TECHNICAL DATA OF SAFETY GLASS</u>	12
<u>OVERVIEW OF ACOUSTIC TRANSMISSION LOSS OF SAFETY GLASS</u>	13
<u>TYPES OF SAFETY GLASS</u>	14 – 18
<u>GLASS GLAZING ACCORDING TO APPLICATION</u>	19 – 20
<u>OTHER USEFUL INFORMATION</u>	21 – 22
<u>TEMPLATES OF GLASS CUT FOR MEASURE</u>	23 – 24
<u>CONDITIONS OF CLAIMING</u>	24
<u>CLAIMS, RESPONSIBILITY FOR DEFECTS OF THE GOODS</u>	26 – 27
<u>NON-REPAIRABLE DEFECTS OF SAFETY GLASS</u>	27 – 28
<u>MATERIAL QUALITY OF SAFETY GLASS</u>	28 – 30
<u>TOLERANCES AND DEVIATIONS OF CROSS-BARS BETWEEN GLASS</u>	31 – 32
<u>TYPICAL GLASS SIGNS</u>	33
<u>THERMAL STRESS</u>	34 – 36
<u>CONDITIONS FOR TRANSPORT, STORING AND HANDLING</u>	37 – 38
<u>INSTRUCTIONS FOR GLAZING</u>	38 – 40
<u>CONDITIONS FOR SAFETY GLASS INSTALLATION – LOCATION OF SUPPORTS</u>	41
<u>GLASS MAINTENANCE</u>	42
<u>PACKING AND HAND-OVER CONDITIONS</u>	43 – 44
<u>CONTACTS</u>	45

HISTORY OF GLASS

It is not known up to now how the glass was found out. The story of the Roman historian Plinius says that it were Phoenician sailors sailing along the African coast who discovered the glass as the first. As they were surprised by night they got ashore and as being very hungry they decided to prepare a soup. Thus they gathered some wood, but they didn't find any stone round the bivouac to underlay it under the kettle for cooking. Therefore they unloaded several stones of natural soda from their vessel they themselves were transporting and set up a provisory fireplace in the African desert full of sand. As they finished cooking the soup one of them noticed that by the reaction of sand and soda and mainly by the high temperature of flames there were some translucent drops remaining in the fireplace. And thus the first glass came to existence. The oldest discovered pearl comes from Thebes and its age is estimated for 5000 years. Although the glass had been already produced in Mesopotamia in the second millenium before Christ. The first findings of glass in the Czech lands date back to the middle of the second millennium before Christ. Small pearls made of blue-green glass are being concerned, found in tombs from the era of Ugnetic culture. Several centuries later, at the beginning of the Iron Age more advanced kinds of glass pearls appear here. Another encounter with glass and glass jewellery is connected with the findings from the era of the Great Moravian Empire. The glass manufacture was a domain of the Church from the beginning, mainly of Benedictine monks who used to manufacture glass for churches and monasteries. The first reference of the manufacture come already from 9th century. The glass works used to produce simple window targets, little pearls and hollow glass.

The existence of the oldest glass works in the Czech lands can be proved by purchase contracts and, indirectly, also by names of several towns and villages, from the second half of 13th century, e.g. Staré hutě (Old Glass Works), Skláře (Glass Works) etc. Another written evidence says even about as late as the beginning of the 14th century. Thanks to the historical sources it can be stated that right this period could be regarded as the prime of the Czech glass manufacture. The oldest mentioning of the first glass works in the area of Jizera Mountains, in Vysoké, dates back to 1376. Sufficiency of wood, water and the raw material for the glass – silica sand – was an important condition for the glass manufacture in the Middle Ages. All these conditions were fulfilled well in the border areas of the Bohemia – Krušné Mountains, Jizera Mountains, Orlické Mountains and the Bohemian Forest. Therefore also the glass making families started to move to these areas. In the Middle Ages the glass was being molten according to the recipe of the monk Theophil from two parts of beech ash and one part of silica sand. The molten glass was colourless, slightly yellow, brown or green. By adding of metallic oxides then it was coloured in blue colour. At the beginning the glass was a precious materiel, later on, when its production was increased significantly, not only other colours were established but also various shapes. In the 14th century first higher goblets with plastic patterns appeared. Under rule of the Emperor and King Charles IV. vitrages of various colours started to be implemented in windows of Czech churches. The glass manufacturers of the Medieval Ages were not just a splendid craftsmen, but, at the same time, also designers and artists. Therefore the glass craftsmen were free of liege obligations. Since 1497 they were incepted among knights and under rule of Rudolf II they could earn a courtesy title.

Plate-glass

Old Romans were not able to produce plate-glass of great size, but in Pompeii and Herculaneum window plates out of casted glass were found. In the first centuries after Christ the glass application was extended very much, and it lasted so till 5th century, when the decline of the Roman Empire started. Several centuries later the glass manufacturers had to reveal the mastery of their ancestors again.

Moon glass

Since the medieval times the flat or plate-glass was manufactured in two ways. According to the first one the glass-blower blew a bulb, then after its separation from the blowpipe he stuck it to a "little iron" and after its heating up again shaped into a disk evoking a full moon. Therefore the name the "Moon glass". Up to 18th century this way the usually used transparent disks inserted in lead were produced for glazing of windows. According to the other way the glass-blower blew a bulb and created a roll which was separated by him from the blowpipe and it was broken lengthwise. After a new heating up the semi-finished product was "ironed" into a plate shape on a chamotte plate. Later the rolls were blown up to 3 metres long with thickness of three millimetres. Already in the Medieval times Czech glassmakers were great at the production of plate glass. It was destined as "Précédé de Boheme" (Lead of Czech lands). At the turn of 19th and 20th century the possibilities of mechanical production of flat glass were searched for. Both the French (Sievert) and the American (Oppermann-Lubbers) way was imitating the manual production out of rolls. The Belgian engineer E. Fourcault gave priority to the vertical drawing of an endless stripe of glass from a tub. The industrial manufacture of the flat glass in Fourcault way was introduced for the first time in the world by J. M. Mühlig in the near Hostomice – it was in 1919.

Float glass

The idea of producing of the flat glass by molten glass floating on a hot metal appeared at the beginning of the previous century for the first time, but it was not adopted. As late as in 1952 the company Pilkington Brothers from England returned to it in order to start the mirror glass production by floating of an endless stripe on surface of a molten metal. In 1966 the licence for the production of the float glass was purchased also by Czechoslovakia. In Sklo Union in Teplice the testing operation on the first line of the Float-Process was started 22nd October, 1969. In the 70th the Float and Spektrofloat glass influenced also the author's glass production and extended the possibilities of its application also in architecture significantly.

COMPANY'S BASIC INFORMATION

- The company was established in 1991 as Sklenařství Martin Volčik (Martin Volcik Glazieri) dealing with services in the field of glass products glazing
- in 2005 the preparation of safety glass production started
- in 2006 the company was transferred in the company SKLENARSTVI NONSTOP s.r.o. and the lot manufacture of safety glass began

ORIENTATION IN QUALITY

ISO 9001:2001

The SKLENARSTVÍ NONSTOP company has introduced the quality management system according to CSN EN ISO 9001:2001 as the first and solely glazieri in the Czech Republic.

- for the safety glass production
- glazier services
- framing and passe-partout mounting

QUALITY OF PRODUCTS AND SERVICES

In our company we put stress above all in quality of the products and services to the customers, which are being made more effective continuously. We use all the available methods and latest technologies leading to enhancing of the activity of SKLENARSTVI NONSTOP s.r.o. Inspections and analyses of all the realization processes are being provided in our company every day leading towards the maximal satisfaction of customers.

COMPANY'S ORGANIZATION CHART

Company's Director	Business Manager
Martin Volčik	Petr Vančik
Production Manager	
Safety glass: Pavel Sedláček	Glass cut for measure, incl. processing Petra Kovařiková
Chief of Administrative	Quality Management
Iveta Kolajová	Jiří Walter

GENERAL INFORMATION

CHARACTERISTICS

The safety glass of the SKLENARSTVI NONSTOP s.r.o. company is being produced by the proven technology of the two-stage sealing (butyl, polysulphide, or polyurethane).

For its excellent features (insulation, sound and sun protection, reflection, safety) the safety glass is used in a wide range in constructions for windows and doors and for the whole-glass facades. In comparison with a simple glazing the safety glass helps to lower the thermal loss by 38 up to 80 % according to the type and execution of the safety glass.

DELIVERY AND COMMERCIAL DATA

- execution of the quotation within 24 hours
- prices don't include V.A.T.
- in case of periodic deliveries the goods is being transported free of charge, in other cases the transport is being solved individually

Maximum producible size of double-glass:

3210 x 2500 mm (or 200 kg max.)

Minimum producible size of double-glass:

200 x 200 mm

Maximum producible size of hardened glass:

2100 x 4500 mm (in dependence on the glass type and thickness)

Minimum producible size of hardened glass:

250 x 100 mm

The double glass above the maximum and bellow the minimum size or the maximum weight – according to the agreement with the manufacturer

Modifications of orders:

After the order has been sent the modifications in the set up order (sizes, etc.) and cancellation can be provided on the basis of our company's expressed consent only.

Delivery term:

According to the specifications (already from 48 hours)

Packing:

- the goods is packed in returnable stands; in case other type of packing is required, it is necessary to state it at the set up of the order
- the borrowed stands will be taken back by the company during the delivery of the next glass supply or they will be returned by the customer for his own costs according to the agreement
- more information in pages 43 – 44

Stands lending

- up to 5 days – free of charge
- over 5 days – lending fee makes 100 Kč /1 day
- maximal term of lending 30 days, if not agreed on otherwise
- in case of breaching of the term for returning thereof the penalty in the whole price of the stand will be invoiced by us

Transport:

In general, the transport is being provided by trucks without unloading – it is recommended to arrange or negotiate for a fork-lift or a crane. The delivery term must be agreed on.

Transport fee:

- a forwarder is secured for the customer's costs
(at the order above 20 000 Kč free of V.A.T. up to 50 km free of charge)
- customer's own transport
- according to contract

Warranty:

5 years for an undisturbed clear view through the safety glass (the warranty doesn't concern the safety double-glass made of decorative glass). For other types of glass the warranty is being provided according to the Commercial Code.

Consultation service:

- free-of-charge advisory at the selection of various types of glass

Claiming:

- see the conditions for claiming in pages 26, 27

TERMS OF AN ORDER

- name, address, ID No. of the company, Tax Reg. No., bank connection and contact person of the Buyer, data on the registry in the Trade Register
- phone, fax, eventually electronic connection
- required term and destination place of the goods delivery (especially when transporting to a building site)
- exact product specification
 - a) glass dimensions – width x height (NOTICE! State the glass width at first!)
composition, amount of pieces, little frame width and gas filling at the double-glass,
processing method (at the simple glass)
 - b) to provide drawings with number codes and all the necessary dimensions at irregular shapes
 - c) the position of glass must be stated at safety glass (decoration, connex) inner or outer view at irregular shapes – in case it won't be stated the view side will be taken as the inner side
 - d) to provide an exact specification of intra-glass grating (width, colour, drawing of positions – cotes of intra-glass grating must be stated from the glass edge to the middle of the grating)
 - e) possible templates must be of more rigid material and described exactly (company name, glass composition, outer view, inner view, etc.)
 - f) way of transport – own or by the supplier
 - g) packing method – standard packing on stands, eventually other according to the agreement

Make sure the order was delivered!

In case you have an inquiry concerning your order, please, contact the commercial department exclusively with the number of your order.

TECHNICAL DESCRIPTION OF THE SAFETY GLASS

1. The glass – all the types of the Float flat glass + special glass
2. Distance frame
– used thickness 6 – 16 mm
– used types: plastic, aluminium, stainless steel
3. Molecule screen – dehumidifier on zeolite basis
4. Butyl – the first stage of double glass sealing, hot applied
5. Two-component polyurethane or polysulfide cement – second stage of safety glass sealing, curing in the air
6. Interspace, filled in by air or gas (argon or krypton, or other gas mixture according to the requirement for the double glass properties).

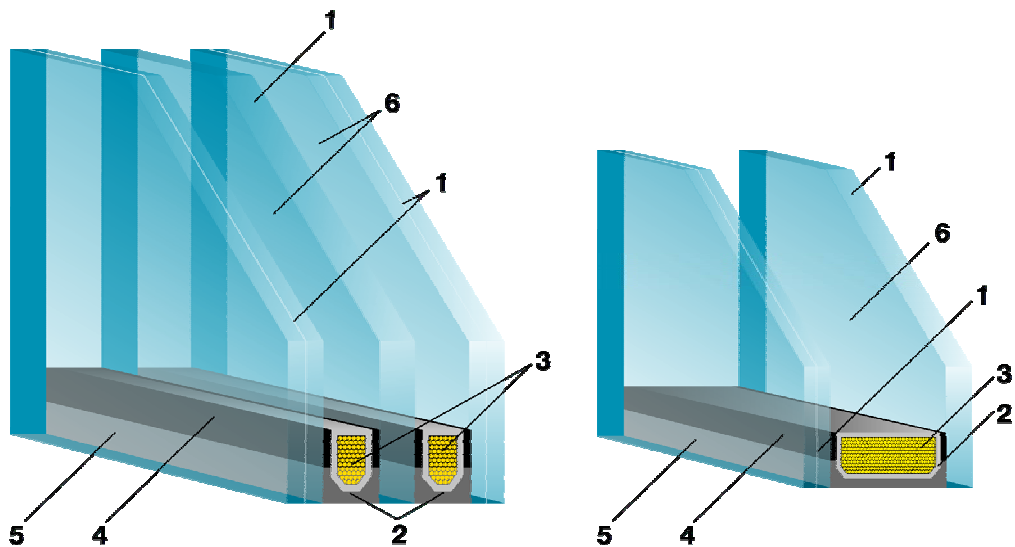

TECHNICAL PARAMETERS OF THE SAFETY GLASS

Type (mm)	Surface Weight (kg/m ²)	Light Transmission in %	Thickness Tolerance (mm)	Size Tolerance (mm)	Max. Recommended of the length side (mm)	Max. Recommended area (m ²)	Max. Recommended Sides ratio
2x4 mm	20	82	+/-1	+/-1,5	2400	2,83	1:6
2x5 mm	25	81	+/-1	+/-1,5	3000	4,5	1:10
2x6 mm	30	81	+/-1	+/-2,0	4000	6,8	1:10
2x8 mm	40	79	+/-1	+/-2,5	4000	10	1:10

Type	Composition	Airspace	Light Transmission in %	U (kw/m ² K)
Single glass	1 x float	-	90	5,34
Safety glass	2 x float	16	82	2,8
Safety glass	3 x float	12 + 12	75	2
Planibel Top N+	float + planibel TOP N	15 - 16	79	1,4
Planibel Top N+	float + planibel TOP + argon	15 - 16	75	1,1
Planibel Top N+	planibel TOP + krypton	10 - 12	69	0,9
GLASSPLATE	planibel TOP + GP + planibel TOP N + krypton	12 + 12	69	0,5

TECHNICAL DATA OF THE SAFETY GLASS

Technical conditions of the delivery are stated in CSN EN 1279.

The smallest producible size of the safety glass is 200 x 200 mm. The biggest size is given according to the static load by the thickness of the used glass and it is given by the size of the weakest plate. For the dynamic load (e.g. by wind) the double glass getting close to the given size must be re-calculated.

The safety glass with dimensions overreaching the size of the production line (2 000 x 3 210 mm, alternatively bent glass), must be regarding the price, composition and production terms consulted with the Commercial Department of the company Sklenarstvi NONSTOP s.r.o.

Maximal weight of the standard double-glass is 200 kg.

Orientation weight of the safety glass:

1 mm glass weights	2,5 kg for 1 m ²
2 x 4 mm	20 kg/m ²
2 x 5 mm	25 kg/m ²
2 x 6 mm	30 kg/m ²
2 x 8 mm	40 kg/m ²

The maximal dimensions of combinations, eventually usage of special glass stated in the PRICE List must be agreed on with the producer in advance (it is valid also for transport of large formats of safety glass – approximately larger than 2 200 mm in the glass height – it is impossible to use the standard transport).

When using big formats of Stratobel glass (layered safety glass), Restex (hardened safety glass) and figured glass (rolled molten glass, with pattern) it is necessary to proceed from the maximal dimensions of these materials given by the technical possibility of the production thereof.

The same concerns the enameled glass and the glass provided by screen-printing or spray coat.

Stratobel (Connex) VSG:

3 210 x 3 210 mm (not valid for shotproof glass, must be consulted)
2 200 x 3 210 mm for Stratobel with Planibel TOP N

ESG Hardened Glass:

4 mm	1 500 x 2 500 mm
4 mm Lowe	1 000 x 2 000 mm
5 – 19 mm	2 100 x 3 600 mm

Ornament:

2 000 x 1 600 mm (must be consulted with SKLENARSTVI NONSTOP s.r.o.)

Print:

Must be consulted with SKLENARSTVI NONSTOP s.r.o.

OVERVIEW OF TRANSMISSION LOSS OF THE SAFETY GLASS

Composition, type	RW (dB)	k (W k(W/m ² oK)	Space filling by gas
4 - 16 - 4	31	2,8 - 1,4 - 1,1	air, argon
6 - 12 - 4	33	2,8 - 1,6 - 1,3	air, argon
6 - 15 - 4	34	2,8 - 1,4 - 1,1	air, argon
6 - 16 - 4	36	2,8 - 1,4 - 1,1	air, argon
8 - 16 - 4	37	2,8 - 1,4 - 1,1	air, argon
8 - 15 - 6	35	2,8 - 1,4 - 1,1	air, argon
10 - 16 - 4	38	2,8 - 1,4 - 1,1	air, argon
Stratobel 44.2 - 15 - 4	36	2,8 - 1,4 - 1,1	air, argon
Stratobel 44.2 - 15 - 6	37	2,8 - 1,4 - 1,1	air, argon
Stratophone 44.2 - 15 - 4	39	2,8 - 1,4 - 1,1	air, argon
Stratobel 44.2 - 15 - 44.2 Stratobel	39	2,8 - 1,4 - 1,1	air, argon
Stratobel 55.2 - 15 - 6	39	2,8 - 1,4 - 1,1	air, argon
Stratophone 44.2 - 15 - 6	40	2,8 - 1,4 - 1,1	air, argon
Startobel 55.2 - 15 - Stratobel 33.2	40	2,8 - 1,4 - 1,1	air, argon
Stratophone 44.2 - 16 - 6	41	2,8 - 1,4 - 1,1	air, argon
Startophone 44.2 - 12 - 8	42	2,8	air, argon
Startophone 66.2 - 15 - 6	42	2,8 - 1,4 - 1,1	air, argon
Stratobel 55.2 - 20 - 6	42	2,7 - 1,4 - 1,2	air, argon
Stratophone 44.2 - 12 - 10	43	2,8	air, argon
Stratophone 44.2 - 15 - 10	43	2,8	air, argon
Stratophone 66.2 - 15 - 8	43	2,8	air, argon
Stratophone 66.2 - 15 - 10	44	2,8	air, argon
Stratophone 44.2 - 16 - 10	45	2,8	air, argon
Stratobel 88.2 - 15 - Startobel 66.2	46	2,8	air, argon
Stratophone 66.2 - 16 - Stratophone 44.2	49	2,8	air, argon
Stratophone 66.2 - 20 - Stratophone 44.2	50	2,8	air, argon
Stratophone 88.2 - 15 - Stratophone 66.2	51	2,8	air, argon

At the glass with U = 2,8 it is possible to supply a better U-value with a different delivery term for a different price than stated in the Price List.

Category	RW (dB)
0	< 24
1	25 - 29
2	30 - 34
3	35 - 39
4	40 - 44
5	45 - 49
6	> 50

TYPES OF THE SAFETY GLASS

► SUN-PROOF GLASS

List of safety double-glass **THERMOBEL®** in various combinations.

Coloured in the compound

Planibel – bronze, grey, green 4 mm, 6 mm
– blue, azure 6 mm

Reflective

Stopsol Classic – with a silver reflection with a slightly succinite touch
– bright 4 mm, 6 mm
– bronze, grey 4 mm, 6 mm
– green 4 mm, 6 mm

Stopsol Supersilver – silver-blue glitter
– bright, grey 5 mm, 6 mm
– green, blue, priva blue 6 mm

Solarbel – transparent reflective glass

► THERMAL-SAFETY GLASS – THERMOBEL®

- coefficient of the thermal transmission for the little frame 15 and 16 mm according to CSN EN 673

U = 1,7 W.m⁻².K⁻¹ Planibel G

U = 1,5 W.m⁻².K⁻¹ Planibel G + argon

U = 1,4 W.m⁻².K⁻¹ Planibel TOP N +

U = 1,1 W.m⁻².K⁻¹ Planibel TOP N + argon

With another little frame the coefficient of the thermal transition U-value is worse.

SPECIAL APPLICATIONS OF THERMOBEL DOUBLE GLASS FOR ROOFS

The main rules which must be followed when glass sealing installation for roofs can be summarized as follows:

1. There should be no direct contact between the glass and the frame

There must be a required space secured between the glass and the frame

- edge clearance: 5 up to 8 mm minimally
- longitudinal clearance: 5 mm minimally
- Minimum 5 cm from the corners two position supports should be located there for each glass.

2. Groove drainage

The grooves should be drained in order no backwater gathers in them; it is to be provided in either of these two methods:

- by drilling of an opening of 50 mm² (the smallest size 5 mm)
- by drilling of 3 discharge openings minimally (1 more opening for each 50 cm in case the glass size exceeds 1 m)

3. Excessive stress avoiding

a) Thermal stress

- the glass should not extend beyond two thermal areas
- grooves or edge protections should not exceed 50 mm
- heating and air-conditioning systems must be designed in the way in order they don't heat the glass
- the double-glass the component part of which is absorbing or reflective outer glass can be hot treated (by hardening or thermal reinforcement) in order the thermal stress caused by high solar radiation intensity will be avoided.

b) Mechanical stress

Groove deflexion should not exceed:

- 1/300 of the length side exposed to dynamic load
- 1/600 of the length side exposed to static load (snow and the self-weight)
- The system of cleaning must be designed in the way it won't be necessary to walk on the glass.

In case of any queries, please, contact the Commercial Department of SKLENARSTVI NONSTOP s.r.o.

4. Protection from UV radiation

The sealing for Thermobel must be protected against UV radiation. In certain installation systems used for roofs the glass edge can be exposed to UV radiation. In such cases Thermobel S is recommended by us, as the silicone sealing is not sensitive for UV radiation.

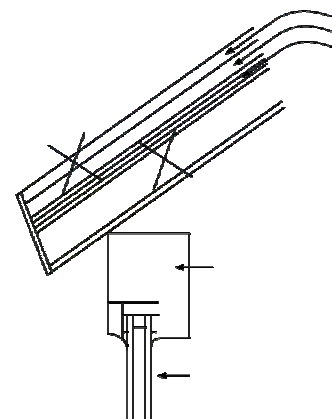

Draft of the double-glass of the roof glazing

THERMOBEL DOUBLE-GLASS FOR SWIMMING BATHS

1. Safety glass application for swimming baths must be stated in the order explicitly, as the spacer sealing should be higher. In this case at least 18 mm (inclusively the sealing), the glass must be in the groove and the circumferential clearance should be 6 mm.
2. The grooves must be vented from the outer side by the help of drilled openings in dimensions of 8 x 25 mm, every 25 cm along the upper and lower side.
3. Positioning supports must be made of hard PVC.

STOPRAY: highly effective protection against admission of the solar energy

Stopray Safir 61/32

Planibel Energy 71/39

$U = 1,1 \text{ W}\cdot\text{m}^{-2}\cdot\text{K}^{-1}$

► ROLLED DECORATIVE GLASS

Clear, bronze, yellow execution, some designs matted

MATELUX – matt glass etched by acid – all the planibel types

LACOMAT – neutral matt translucent appearance, evoking sanded glass

► SOUND INSULATING

- individual composition, sound damping and heat transmission coefficient “U” – see the table
- we can deliver calculation sheets to all the stated compositions, protocols to some of them

► ANTI-FIRE – PYROBELS

PYROBELITE – FIRE RATING EW 30

PYROBEL EI 30/16 – fire rating EW 45, EI 30

► SAFETY GLASS

Glassplate®

- shotproof glass – projectile calibre 9 mm – BR-2 category
- strong sound protection – reduction by 50 dB
- unbreakable – the highest category EN 356 – P5A
- with extremely high thermal insulation – heat transmission coefficient K up to 0,5

All these features have been, naturally, certified by the authorised testing institute IKATES, s.r.o. with its seat in Teplice.

The safety system is fully unbreakable, therefore it prevents violent invasion into the object. It is an ideal solution for glassed facades, winter gardens and other glass constructions, requiring the grade of safety and thermal insulating features at the same time. Thanks to its low weight and thickness GLASSPLATE is suitable for production of plastic windows and doors, wooden EURO-windows, etc.

Stratobel

STRATOBEL layered glass is an excellent construction element for safety glazing (protection of persons and objects against damage, fraud and violent attacks).

- reduces sun glare, reflects heat, absorbs sounds, reduces transmission of UV radiation
- in case the glass is broken, the splinters remain on the foil and thus the injury of persons is reduced or fully eliminated
- according to the particular categories of the safety class the layered glass puts up resistance
- against violent breaking into the object

Layered glass **STRATOBEL** (CONNEX) – the most used combination

33.1 (foil 0.4 mm) - 6,4	$R_w = 32$ dB
33.2 (foil 0.8 mm) - 6,8	$R_w = 33$ dB
33.4 (foil 1.5 mm) - 7,5	
44.1 (foil 0.4 mm) - 8,4	$R_w = 34$ dB
44.2 (foil 0.8 mm) - 8,8	$R_w = 35$ dB
44.4 (foil 1.5 mm) - 9,5	
33.1 (milk foil 0.4 mm) - 6,4	
33.1 (foil 0,4 mm) - 6,4 with Planibel TOP N	
44.2 (foil 0,8 mm) - 8,8 with Planibel TOP N	

Layered glass **STRATOBEL** shotproof, resistance category according to EN 1063

BR 2 – S (C1SA)
BR 3 – S (C2SA)

Layered glass **STRATOPHONE** (CONNEX) with a special sound-proof foil

44.2 (foil 0,8 mm) - 8,8 - $R_w = 37$ dB
66.2 (foil 0,8 mm) - 12,8 - $R_w = 39$ dB

Hardened thermally strengthened glass

all planibels, stopsols, ornaments, enamels

Common armoured glass

Interior armoured glass (fire-protecting) PO 30

ESG

hardened – high stability against float and resistance against sudden temperature changes, when breaking - small, not sharp fragments

TVG

semi-hardened – higher stability against float and resistance against temperature changes, the glass breaks in big fragments and thus it doesn't come to tilting out of frames.

STRATOBEL (CONNEX) GLASS – SAFETY CLASS

DIN EN 356

Resistance against breaking, vandalism and breaking-in

Testing method No. 1: free-fall of a ball (4kg) – the given glass must withstand three strokes

Testing method No. 2: axe strokes (2kg) – the given glass must withstand it

Class	STRATOBELU composition	Testing method	
		No. 1	No. 2
P1A	STRATOBEL 33.1	1, 5 m	3
	STRATOBEL 55.1		
	STRATOBEL 66.1		
P2A	STRATOBEL 33.2	3 m	3
	STRATOBEL 44.2		
	STRATOBEL 55.2		
	STRATOBEL 66.2		
P3A	STRATOBEL 44.22	6 m	3
P4A	STRATOBEL 44.4	9 m	3
P5A	STRATOBEL 44.222		3
P6B (B1)	4 - 0,76 - 4 - 0,76 - 4 - 0,76 - 4		30 - 50
P7B (B2)	4 - 0,76 - 4 - 0,76 - 4 - 0,76 - 4 - 0,76 - 4		51 - 70
P8B (B3)	Up to now not tested		Over 80

(B1, B2, B3 – according to DIN 52 290)

DIN 52 290 (EN 1063)

Shot resistance of a simple glazing

With fragments flying

Resistance category	Total thickness	Type and calibre
C 1 SA (BR 2 S)	21 mm - 23 mm	9 mm
C 2 SA (BR 3 S)	26 mm - 28 mm	Magnum 357
C 3 SA (BR 4 S)	31 mm - 33 mm	Magnum 44
C 4 SA	57 mm - 61 mm	7,62 mm / 9,45 g
C 5 SA	61 mm - 65 mm	7,62 mm / 9,75 g

In case fragments mustn't fly away STRATOBEL will be added to the double-glass.

DIN 52 290 (EN 1063)

Explosion resistance of a simple glazing

Resistance category	Composition, Total thickness	Weapon type and calibre
D1	44,6/10,28	Against terrorism, bombs, explosion
D2	4444,222/18,28	Army buildings

GLASS GLAZING ACCORDING TO APPLICATION

STRATOBEL DOUBLE-GLASS

Regarding the fact that this glass is a combination of several glass plates, cemented to each other by PVB (polyvinyl butyral), the method mustn't effect their glazing or to impair their conjunction.

Therefore:

1. The layered glass edges mustn't come in contact with organic solvents neither with water.
2. Cements must be compatible with PVB.

STRATOBEL double-glass – breaking-in prevention:

This glass is constructed for the protection of people and property. There are two ways how to get through this glass:

- the first one is to break the glass (though the layered glass is very difficult to break)
- another way is frame damaging

We recommend to locate the layered glass in the direction into the building interior part.

Note: In order to follow the condition of Point 1, only the grooves with drain can be used in combination with this product.

In case the glazing battens are outside, the glass must be glazed in the wet process in order it creates an integral unit with the frame (by application of silicone cement or other material of similar kind).

There are three ways how to break in into the object without the safety glass breaking:

1. Pushing the glass out of the frame:

It can be avoided by double-glass installation into deep grooves. On top of that the system must be used making one unit out of the glass and frame, best of all by the help of silicone sealing or other material of similar kind.

2. Partial disassembly of the set:

It can be avoided by location of the glazing battens in the direction into the building interior part.

3. Frame removal:

For avoiding of the damaging of this type special turning and blocking tools are being used. A special attention must be devoted to anchoring of the frame into the walling.

The glass is only one of the elements of the safety protection. Also pertinent safety frame must be used.

It is recommended by us to install the layered glass in the direction into the building interior part.

GLASS FLOORS (WALKABLE GLASS)

At present the glass is being used also as the material destined for filling of the floor areas. The glass floor sheets transmit light into lower areas and vice versa, a lighting can be installed in them.

- single layered glass can be used
- glass floor mustn't be accessible for cars
- every tile must be located on 4 supports

Installation

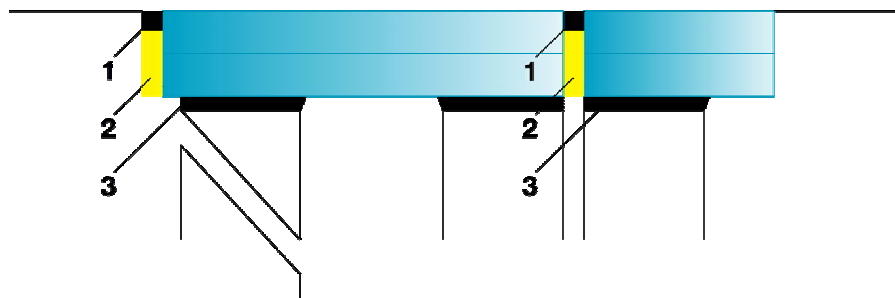

1. elastic sealing material
2. positioning of the sealing material (polyurethane foam)
3. strip of the rest (hardness according to Shore A 85)

Special recommendations

- if the glass is wet it is slippery
- with nailed shoe soles and by materials which can be stuck in the sole pattern and the hardness thereof is higher than the glass hardness the glass can be scratched (e.g. little flint stones)
- plate edges can be split off by effect of high heels
- the scratched or split off sheets can break, but there is no manufacturer's warranty applied to
- glass tiles are destined for walking, in no case can cars drive on it
- the floor mustn't be exposed to a massive static load (furniture, statues)
- for illuminated tiles the following is valid:
 - The maintenance and repairs of lightening mustn't require dismantling of tiles
 - The illuminators shouldn't create areas with excessive local heat which could cause tiles breaking because of thermal stress
- It is necessary to provide a corresponding illumination type, effective venting and sufficient distance between the lamp and the tile
- The compatibility of all the materials and components must be verified

OTHER USEFUL INFORMATION

▶ FILLING WITH GAS

For further improvement of thermal-insulating features (heat transmission coefficient “U” – W.m – 2.K – 1) the glass is being filled with gas. Argon filling improves the thermal-insulating features.

▶ ORIENTATION OF THE DECORATION

The decoration in the double-glass is orientated always into the inner space of the double-glass. There are some exceptions as e.g. ornaments Niagara, Bambo and Bucny, and naturally, for the customer’s requirement. When decoration glass ordering, please, state always the ornament orientation – vertical or horizontal.

▶ LITTLE DISTANCE FRAME

The distance between safety glass is limited by a little distance frame, which is bent in the corners or connected by little plastic corners. The width of the little distance frame makes (in mm): 6, 8, 10, 12, 14, 15, 16, 18, 20 and 22.

Warm edge:

- stainless steel little frame Chromatech plus – of the width 12, 14, 16 18 mm.
- stainless steel-plastic profile TGI – W of width 12, 14, 16 18 mm, colour light grey, light brown

▶ DECORATIVE PARTITION GRATINGS

From the point of view of the aesthetic feature and disposition of the composition area the partition decorative gratings are being used, which are of various widths and thicknesses. Their wide scale of colours is at disposal. Clapping of the internal partitions on the glass when handling with the windows or doors or rattling when heavy trucks go by on a near road is not to be considered for a fault, this effect arises from the production technology and used materials of the gratings. Every customer must count with clapping of the grating, it’s no reason for claiming of the safety double-glass. For the clapping restriction silicone lenses are being used, which are to be stuck on the grating crossing.

When the silicone lens are being used, it can come to the following:

- to pressing of the silicone lens and to its successive breaking
- to shifting of the silicone lens on the round surface of the grating, rarely to its falling down

When using of the silicone lens the utility value of the safety double-glass or its thermal-insulation features are affected no way. The customer must be advised of these potentialities and it must be left for his decision whether he will require the silicone lenses or not. The above mentioned problems with the silicone lenses are no object for claiming of the safety double-glass.

Any grating or DUPLEX deteriorate the heat transmission coefficient and nowhere it is stated by how much. As a matter of fact these elements create the thermal bridge in the middle of the double-glass. The double-glass with DUPLEX is not being filled with gas by us. In case you will order DUPLEX double-glass, please, don’t ask us to fill it with gas. To customers offer the value of U = 1,4 for DUPLEX. For all the glass with a grating or DUPLEX glass we are not going to state the heat transmission coefficient for the little frame, but the marking THERMOPLUS only, possibly the gas filling – with AR (argon).

In standard cases the silicone lenses are not being used by our company since 01. 01. 2007, just for a customer’s requirement in written.

► SAFETY GLASS STORING

The glass must be stored in a dry, covered area, protected from climatic influences and direct solar radiation, mechanical damage of edges, etc. The safety glass is being stored always on the edge and upright to the base, whereas the base is in a slight inclination: 10 – 15 degrees. Inter-linings should be inserted between particular glass which will prevent mutual contacting of the glass. Cork inter-linings or other elastic material is being recommended. The inter-linings should be positioned in the corners approximately 5 cm far from the glass edge. At bigger formats the inter-linings must be located also in the middle of the glass area. Between the safety glass of various area sizes minimally two vertical battens must be inserted.

Maximum number of safety double-glass which can be leaned in one line one after another the following results out of the area size of the largest double-glass:

up to 1,5 m ²	20 pcs
1,5 – 2,0 m ²	15 pcs
over 2,0 m ²	10 pcs

► GLASS THICKNESS FOR THE GIVEN AREA

Double-glass sizes – limits:

- 4 – 16 – 4 maximum production size 1600 x 1600 mm
area 2,56 m²
one side length 2500 mm
- 5 – 16 – 5 maximum production size 2000 x 2500 mm
area 5 m²
one side length 3000 mm
- 6 – 16 – 6 maximum production size 2500 x 3500 mm
area 6 m²
one side length 3500 mm

For application of the cemented safety glass STRATOBEL we shall find out the usable calculated thickness when the thickness of one glass in Stratobel will be multiplied by the square root of two: the calculated thickness for Stratobel 33.1 (6,4) = square root of 2 x 3 = 4,2 mm.

► NOTICE FOR GLAZING

Always use a proper cement for safety glass glazing (and cementing of rests, too), which is compatible with the used cements in our safety glass production. Don't use acid or neutral cements on OXIMES base. Butyl can be damaged also in case the cement or dye or lacquer of the frame are not in a direct contact with the cements on the circumference of the safety glass. It is necessary that the person glazing the safety glass always asks the silicone cement producer whether it is acceptable for his concrete application. The details on the method of glazing of the double-glass, safety glass or laminated glass can be acquired in the Appendices.

TEMPLATES OF GLASS CUT FOR MEASURE

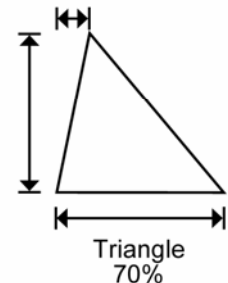
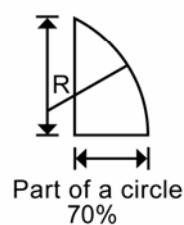
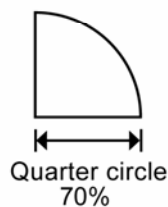
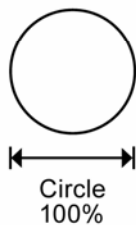
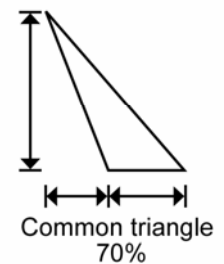
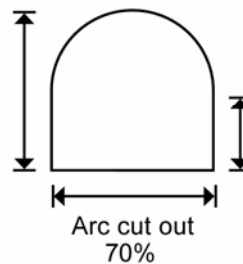
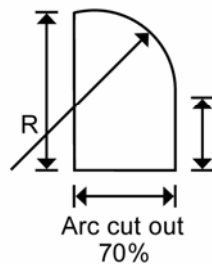
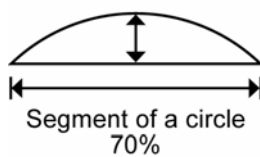
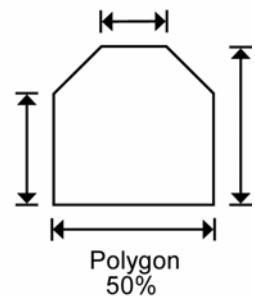
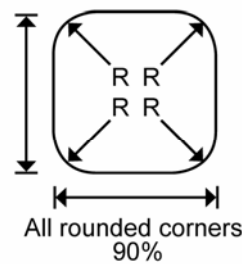
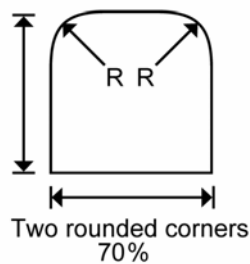
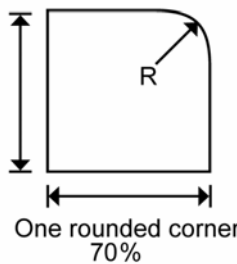
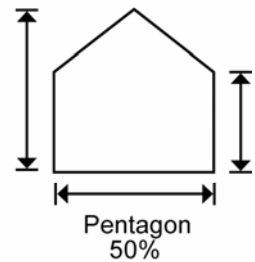
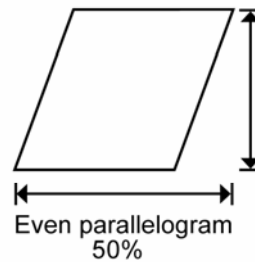
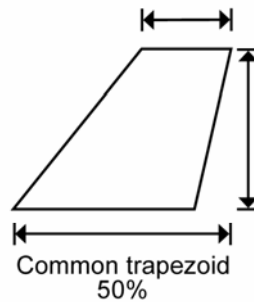
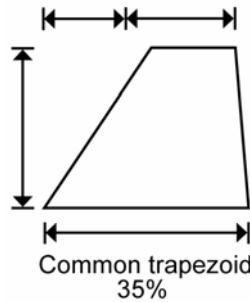
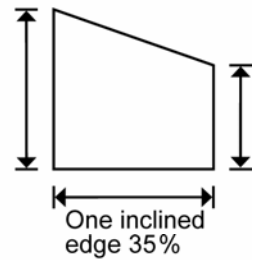
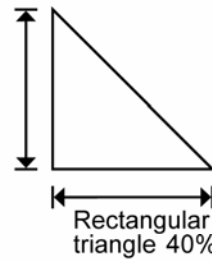
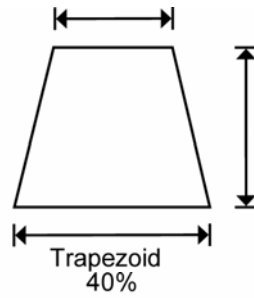
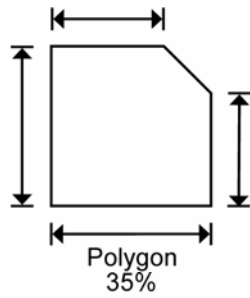

Templates - surcharge 100%

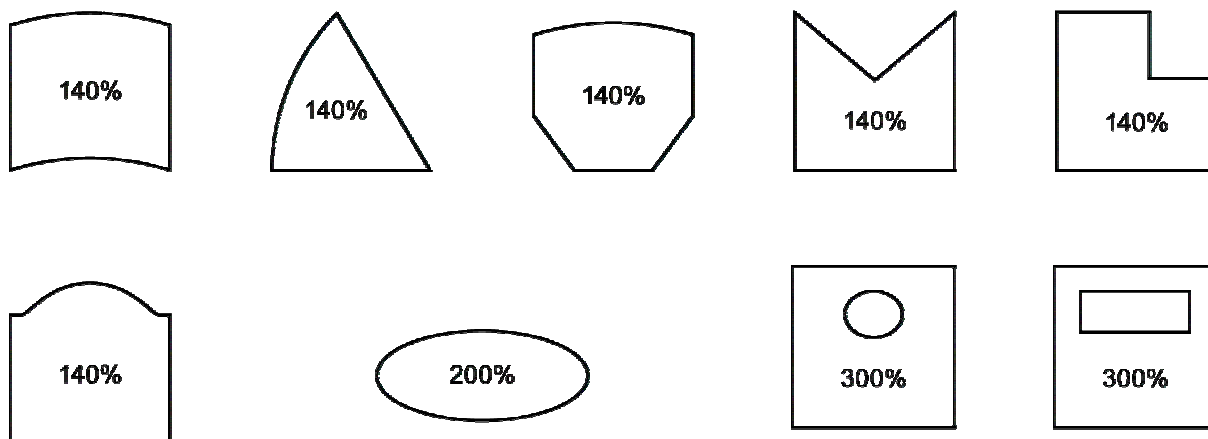

Data stated in the template take the precedence over the data in the order.

CONDITIONS OF CLAIMING

- Possible claims can be admitted only in the case of following of the stated conditions of storing and handling. The defects caused by an improper product application can't be admitted.
- Each buyer of glass must create corresponding storing conditions whereas he secures the long-term service life of the glass and thus speeds up the possible claiming procedure.
- When claiming a glass the assessment of the defect must be enabled to our representative in your company's premises. In extraordinary cases it is possible to visit the customer's premises; in case the visit of our representative in the site of the claiming is groundless (defects can't be admitted as a claim), the cost of the journey will be covered by the claimant.
- In case the claim is grounded the defect will be repaired by us; in case the repair of the defect is impossible a new product will be supplied by us.

BELONGINGS OF A CLAIM

1. No. and date of the original order
2. invoice No.
3. claim reasoning
4. amount of claimed pieces of glass and their specifications
5. address, where the claimed glass can be assessed

DEFECTS CLASSIFICATION – SAFETY GLASS

Apparent defects

- Caused by the supplier during the transport (e.g. broken glass) must be recorded in the delivery note immediately when taking over of the order. Later claims of this defect won't be admitted.

Other defects

- spot or area defects of the glass
- impurities inside the safety double-glass
- defects of the intra-glass gratings, etc.

Hidden defects

- Among these defects belongs moisture condensation of safety glass in the intra-space. The manufacturer – Sklenarstvi NONSTOP s.r.o. takes the guarantee for a clear undisturbed view free of moisture condensation inside the double-glass for the term of two years since the product delivery in case the condition of storing, transporting and erection have been followed.

Attention! At the defect assessment we consider CSN EN 1279 which is followed by the manufacturers of plate glass and by the suppliers of materials for the safety glass production.

CLAIMING TERMS

Claiming of the goods must be provided in the terms as follows:

- apparent defects (e.g. broken glass) – immediately at the goods take over
- other defects – to claim immediately after the defect has been found, not later than 15 days from the goods take-over

CLAIMS, RESPONSIBILITY FOR DEFECTS OF THE GOODS

1. The Seller will provide all the goods with the basic warranty in the length of 24 months.
2. The goods warranty is conditioned by its proper transport, storing, handling and installation according to the generally valid rules. The principles of the proper storing, handling and using of the products are published in web pages www.sklenarstvinonstop.cz.
3. The warranty won't be admitted in case the defect was caused by the buyer from any reason, especially by breaching of the following rules:
 - no intervention into the safety glass construction can be made
 - when safety glass setting into the construction the required dilatation joint must be kept
 - the safety glass size mustn't be modified additionally
 - the safety glass mustn't be in a direct contact with the construction of the opening (e.g. window) frame
 - construction of the opening must be dimensioned and anchored in the way not to be deformed and thus it is not coming to the mechanical stress of the safety glass
 - the glazing groove must be cleaned, dried and degreased
 - the glazing groove must be deep sufficiently in order to cover the distance little frame
 - the glazing groove must be drained and deaerated in order the air circulation in the setting of the safety glass is secured
 - the width of the glazing supports must be selected properly and the supports must be set in the way that both glass would be supported at the same time and in case it comes to the transfer of the glass weight into the cement and the little frame
 - the whole-circumferential both-side-cementing must be elastic permanently, tight, resistant against weathering effects and fluctuations in temperature
 - the applied cementing material shouldn't be aggressive, must prevent from moisture penetration into the groove area and it must have a good adherence to the materials it will come in contact with
 - immediately after installation the inscriptions, labels, etc. should be removed from the safety glass
 - the smallest permissible distance of the both-side-cementing of the circumference of the safety glass from heating bodies is 30 cm against the glass area
 - it is allowed to glaze just the glass which is free of apparent defects
 - for glazing of the double-glass with silicone always neutral silicone must be used, recommended by the manufacturer for this purpose; some silicones can affect the consistence of the primary butyl cement
4. Every claim of a product, goods or service must be passed over by the buyer immediately after the defect finding in a written form to the address of the seller's company with the claim reasoning, at the latest as follows:
 - for the quantity, refraction and outer scratches – during the goods take-over at the latest
 - for apparent defects – scratches inside the safety glass, other dimension, faulty execution, etc. 15 days max. from the day of the goods receipt by the end-user immediately after installation
 - for hidden defects till the end of the warranty term at the latest

5. The seller reserves the right to decide on justice of the claim after the goods take-over what must be enabled by the buyer.
6. The seller will not admit any claim and defects in case the conditions of the goods usage doesn't conform with the technical standards CSN; or with the general conditions of installation, which are known for the usage of the given kind of the goods.
7. The seller can chose at the admitted claim in what way he will satisfy the claims from defects – either by the delivery of spare or missing goods, repair of the goods or by reasonable price reduction, or by removal of legal defects of the goods.
8. The seller is not obliged to satisfy the claims from the goods defects in case the buyer is in default in payment.
9. In case the goods will be produced of the material or raw material supplied by the buyer the seller won't be responsible for the quality of the supplied goods.
10. The following is not regarded as a defect: see the non-repairable defects of the safety glass.
11. In case we work with the customer's glass (cutting, drilling, grinding, cementing of the double glass, etc.), no responsibility for its damage or breaking is taken by us. Similarly, no guarantee relates to such glass or product.
12. The following is not regarded as a fault:
 - Tolerance for splits off from the little frame 2-3 mm
 - Butyl on the little frame not exceeding 3 mm or a capillary shorter than 5 cm is just a cosmetic fault, so it's not a reason for claiming.

NON-REPAIRABLE DEFECTS **OF THE SAFETY GLASS**

The following is not regarded as a defect:

Occurrence of interferences

Interferences in a form of spectral colours can arise in the safety double-glass. Optical interferences are a characteristic feature lapping of two or more light waves at meeting in one point. They arise coincidentally and they can't be influenced.

Double-glass effect

Safety double-glass has an enclosed air volume the condition thereof is stated by barometer air pressure. After installation, at changes of the temperature and air pressure a short-term concave or convex deflection of particular sheets and thus also an optic distortion arise. This effect is a physical regularity of all the insulation units. This effect is most visible at the glass with enhanced light reflection (by mirror).

Glass wettability

Surface wettability of the outer safety glass can be varying, e.g. because of the transfer of a roller, fingermarks, labels, by smoothening agent, etc. When the glass surface is wet caused by moisture condensation, rain or water when cleaning, the different wettability can be apparent.

Anisotropy of the hardened glass

It arises at the glass treated by tensioning process. By various zones of stress double refraction of the shaft of light arises, the spectral colour rings, cloud patterns, etc. become visible. The anisotropy shows by disturbing optical effects on the hardened glass, which become more apparent at certain light conditions and polarized light. They show themselves as various patterns and ornaments. This effect is physically conditioned and characteristic for the hot treated glass and is no subject for claiming. It arises as the double-refraction effect in the glass of a different stress in its cut section.

Optical deformation of the hardened glass

In the course of the hot treatment the hot glass is in contact with ceramic rollers where it comes to the deterioration of the glass asperities, to a surface deformation known as the “roller wave”. The roller wave can be seen in the reflection. The glass the thickness of which is over 8 mm can exhibit signs of tiny imprints in the surface.

Crack in glass

The main reason is especially an improper storing and handling at the buyer’s (on building-sites, transport in horizontal position, etc.), improper way of glazing, wrongly determined safety glass width regarding the glazing half-groove (small space), when applying outer foils and glued battens. Also thermally induced stress or the motion of the frame construction, resp. contacts with the construction when using can lead to the light refraction. Safety glass with duplex mustn’t be exposed to freezing temperatures (unfinished constructions where it comes to concave deflection) and thus to breaking under duplex. If the tension or glass breaking were present before processing it wouldn’t have been possible to process it, it wouldn’t have been possible to cut the glass and it wouldn’t have gone through the press where the pressure is over 3 bar.

MATERIAL QUALITY OF THE SAFETY GLASS

Deviations of dimensions (according to CSN 70 1621).

Maximum deviation of the width and height of the glass of the safety glass:

- up to the length of 1 m +/- 1 mm
- up to the length of 2 m +/- 2 mm
- over the length of 2 m +/- 3 mm
- triple glass, decorative glass +/- 2,5 up to 4 mm

Maximum deviation of the total thickness of the safety glass in composition:

- double-glass +/- 1 mm
- ESG double-glass, VSG – connex +/- 1,5 mm
- triple-glass and decorative glass +/- 2 mm

For the safety glass the following is valid:

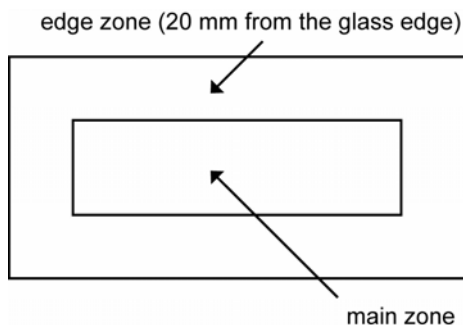

Permitted defects:

1. Grooves are permitted for the edge zone
 - flat defect situated outside – mussels not affecting the glass strength
 - flat defect situated inside – mussels not affecting the glass strength
 - scratches – unlimited
2. Main zone:
 - see Permitted defects of a flat glass

PERMITTED DEFECTS OF A FLAT GLASS

Routine inspection

it is being assessed from the distance of 1 m by view-trough in the direction of application

General inspection

in what angle and from which distance – in case of capillary scratches only

Defect type (indicators)

gas holes

closed, transparent

closed non-transparent and open

little stones

scratches up to 20 mm

like hairs

coarse

allowed range without limitation

up to 0,6 mm without limitation, but not in clusters

up to 2,0 mm – 4 pcs

up to 3,0 mm – 2 pcs

up to 5,0 mm – 2 pcs

not allowed

not allowed

without limitation, but not un clusters

up to 50 mm – 7 pcs

up to 100 mm – 5 pcs

not allowed

Mutual distance of the defects at least 20 mm.

TOLERANCES OF SINGLE THICKNESS

Single thickness (mm)	Tolerance (mm)
2	+/- 0.2
3	+/- 0.2
4	+/- 0.2
5	+/- 0.2
6	+/- 0.2
8	+/- 0.3
10	+/- 0.3
12	+/- 0.3
15	+/- 0.5
19	+/- 1.0
25	+/- 1.0

CATEGORY OF POINT DEFECTS

Category	Dimensions of the core of point defects (mm)
A	$> 0.2 \text{ A} \leq 0.5$
B	$> 0.5 \text{ A} \leq 1.0$
C	$> 1.0 \text{ A} \leq 3.0$
D	> 3.0

LEVEL OF THE TAKE-OVER FOR POINT DEFECTS AT THE SECTIONAL DIMENSIONS

Defect category	Average 20 m ²	Maximum in each plate
A	any quantity	any quantity
B	3	2
C	0,6	1
D	0,05	1 – defects leading to refractions are not allowed

Note – the word “average” relates to setting of a cumulative average of the last 20 tons of glass.

POLISHED GLASS WITH WIRE INSERTION – CSN EN 572 – 3

Single thickness (mm)	Limit values (mm)	
	Minimum	Maximum
6	6,0	7,4
10	9,1	10,9

ILLUSTRATION OF TYPES OF WIRE DEFLECTIONS

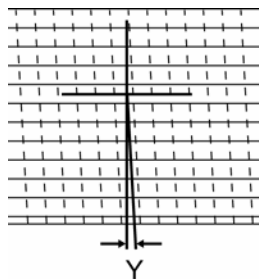

Non-rectangularity

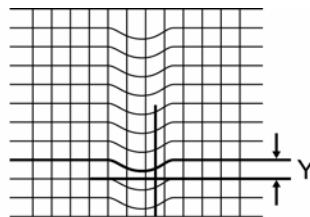

Waviness

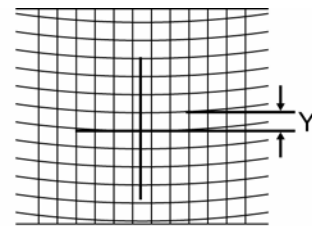

Deflection (in arch)

POINT DEFECTS

1. Spherical and quasi-spherical defects occurring in the contact with the wire or in the distance from the wire < 2 mm.
In case the bigger size is < 2,0 mm they are acceptable without limitation.
In case the bigger size is < 2,0 mm < 4,0 mm they are acceptable up to 0,5 defects in m².
They are unacceptable in case the bigger size is > 4,0 mm.
2. Spherical and quasi-spherical point defects occurring in the distance from the wire insertion > 2,0 mm.
In case the bigger size is < 1,0 mm they are acceptable without limitation.
In case the bigger size is > 1,0 and < 4,0 mm they are acceptable up to 0,5 defects in m².
They are unacceptable in case the bigger size is > 4,0 mm.
3. Lengthwise point defects of width < 1,0 mm
In case their length is < 1,0 mm they are acceptable without limitation.
In case their length is > 1,0 mm and < 5,0 mm they are acceptable if their amount is < 3 in m².
In case their length is > 5,0 mm and < 10,0 mm are acceptable if their amount is < 2 in m².
They are unacceptable in case their length is > 15,0 mm.
4. Lengthwise point defects of width > 1,0 mm. In case the bigger size is < 4,0 mm they are acceptable up to 0,5 defects in m². They are unacceptable in case their bigger size > 4,0 mm.

TOLERANCES AND DEVIATIONS OF CROSS-BARS BETWEEN GLASS

DIMENSIONS DEVIATIONS

Maximum deviation of the field grid:

- up to 1 m of the length +/- 2 mm
- above 1 m of the length +/- 3 mm
- the same tolerances for deflection
- maximum deviation of the cross and other joints +/- 1,5 mm

Scratches, stains, burrs, impurities

- non-recognizable by casual look from the distance 1 m allowed
- at bended intra-glass bars permitted deformation of the bar profile in the shape + slight profile waving, which is given by physical features of the material

DEVIATION OF THE DISTANCE FRAME AT THE SAFETY GLASS

- up to 1 m of the length +/- 2 mm
- above 1 m of the length +/- 3 mm
- the total width of the distance frame incl. the cement (polyurethane) mustn't overlap the edge
- 1,5 mm from the glass edge

WATER CONDENSATION ON OUTER SURFACES

CSN EN ISO 1279 – 1 GLASS IN CONSTRUCTION – SAFETY GLASS in the Appendix the following is stated:

C.3 Outer condensation

Outer condensation on the safety glass can be apparent both inside and outside the building. In case it comes to it inside the building mostly high moisture together with low outside temperature in the room is being concerned. Kitchens, bath-rooms and other rooms with high moisture are sensitive especially. In case it comes to it outside the construction the condensation caused by the temperature loss of the outer surface of the glass radiated by infra-red radiation towards the clear sky at night together with the high moisture of the outer atmosphere, but not the rain, is being concerned.

These effects are no defects of the safety glass, they are caused by atmospheric conditions.

The condensation moisture can be created on the outer glass surface only in case the glass surface is colder than the adjacent air (e.g. the dewy car screens).

CONDENSATION ON THE INNER SIDE

Condensation moisture on the glass plate surface in an interior part of a building is being supported by restraint of the air circulation, e.g. by a deep window lining, curtains, flower-pots, window shutters and also by improper alignment of the heating elements, by an insufficient ventilation, etc. Proper design of the window positioning in the construction of the external cladding together with the proper design and execution of the connection detail of the window to the cladding must be provided. Also the depth of the glazing groove is an important factor (embedded glass in the window profile – the deeper the better). The biggest fault is an improper window position – in ideal case it should be located in the middle of the circumferential sheathing thickness and outside the connection detail must be insulated properly. The non-insulated brickwork and window sill themselves cause profile cooling and formation of the non-proportional condensate quantity!

CONDENSATE ON THE EXTERIOR GLASS SIDE

At the safety glass with a high thermal insulation the condensate can create temporarily on the outside glass surface, when the relative humidity of the outside air is high and the air temperature higher than the temperature of the outer sheet surface. It's a prove of a high insulation rate of the glass – it doesn't transmit the heat outside – it doesn't warm up the outside sheet.

As a clear prove serves the glass with intra-glass gratings, where in the place of the gratings the condensate is not created – outer sheet in the place of the grating is warmed up by the heat lead in them.

PHYSICAL FEATURES OF THE HARDENED SAFETY GLASS

Optical deformation

As the hot glass is in contact with the rollers during the hot hardening and thus it is coming to deterioration of the surface flatness, to the surface deformation known as the “roller wave”. Generally, the roller wave can be recognized in reflection. The glass the thickness of which is higher than 8 mm, can show marks of tiny surface imprints.

Anisotropy (irisation)

During the process of hardening the areas with different tension in the glass cross-section arise. These areas of tension create the two-refraction effect in the glass, which is visible in polarized light. In case the hot hardened safety glass is viewed in the polarized light, the areas of tension appear as coloured zones, known sometimes as “leopard spots”.

Polarized light exists also in normal daily light. Volume of the polarized light depends on weather and the position of the sun. The two-refraction effect is more apparent in view in a sharp angle or when viewing through polarization glasses.

The production claiming on the basis of a template (e.g. shape, position of openings, cut-outs, etc.), which was returned to the customer, won't be admitted.

TYPICAL GLASS SIGNS

CLEAR GLASS FADING OUT

Common clear glass shows always a slight fading out when light gets through it. This feature cannot be thought apart from the basic composition of this glass. The higher the thickness the bigger the fading out.

COLOUR SWINGING IN THE GLASS WITH A PROTECTION LAYER

The glass with a protection layer shows a special fading out apparent when the light gets through or reflects. A slight colour swinging in the protection layer is a natural effect of the production procedure.

NOTICES

Optical deformations at reflection as follows:

1. Reflection on a convex or hollow surface

Independently on the fact whether the safety or protection glass is a component part of the double-glass or not, the double-glass under the given temperature and pressure contains a certain volume of air or gas (argon, krypton, etc.).

In case of a change of the outside temperature or barometric pressure the air pressure contained inside the double glass rises or drops. The two sides of the double glass will have a convex or hollow shape. This effect caused by fluctuation of the air or gas volume represents a function of the changing outside climate. It can't be regarded as a fault.

2. When the frame attaching

All edges of the safety glass which are not attached in the frame evenly can cause deformities apparent at reflection.

3. Hardened, layered, thermally reinforced or fire-protecting glass

Optical deformations proper to the given procedure can appear and it's not possible to prevent them.

THERMAL STRESS

Stress of thermal origin can arise in the glass (single and multiple as well) in case there will be a temperature difference between two various points of its surface.

Two items, causing this effect are as follows:

1. solar radiation

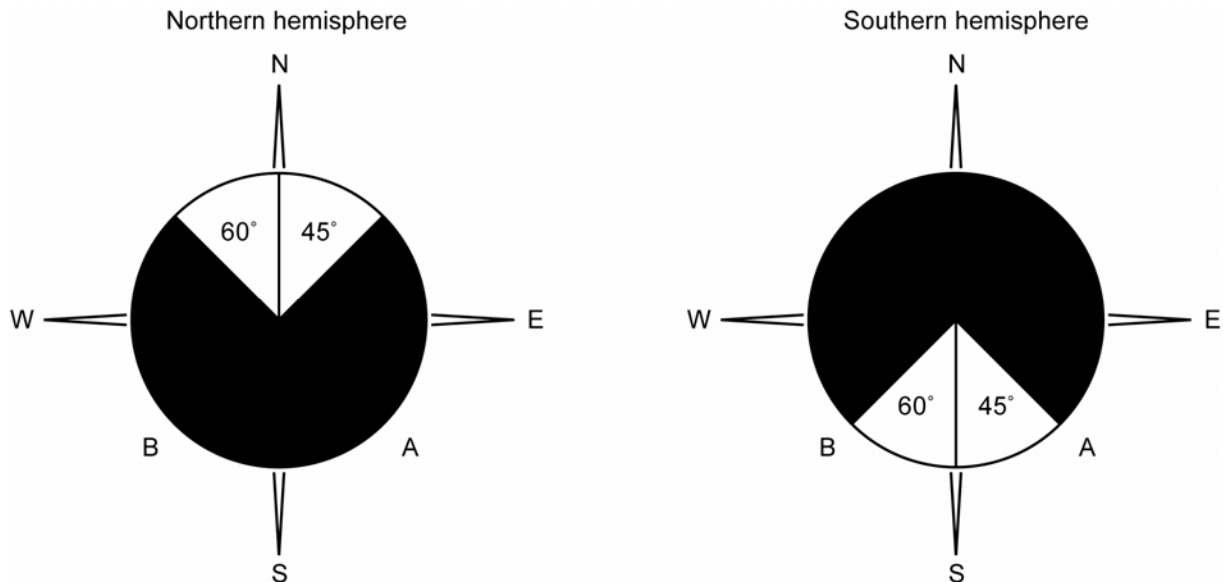

The influence of the solar radiation will differ in dependence on the glass orientation. Vertical sight glass are exposed to the solar radiation the orientation of which is in illustrated pictures contained in the shaded fields.

2. System of air-conditioning and heating in the interior

Accidents can be caused e.g. by direct heaters (flames of burners).

In case the glass will be exposed to the solar radiation evenly, then, theoretically, no thermal stress will arise in the glass if the temperature is the same throughout the whole area. In practice it is not valid mostly, as the glass is attached in a groove or it is in shadow by other building against the facade of the building itself. That's the reason why the sill glass always must be thermally reinforced or hardened.

The air in the rooms used by people is conditioned or heated up by heating bodies, located close to the windows. These heating bodies can work on the base of a liquid (water or oil) or a gas (suction units).

The following table shows an overview of typical thermal stress.

INTRODUCTION TO THE TABLE

Temperature differences stated in the table cause mechanical stress in the glass.

Temperature differences caused by solar radiation are being caused by the glass absorption features in a great mass. The arisen stress can be calculated on the basis of the building facade orientation, latitude of the locality and further parameters, which are described in the following table of thermal stress.

In case the degree of the glass absorption reaches 50 %, the thermal stress must be considered. It means according to the glass processing in many cases.

Systems of conditioning and heating can create hot or cold points on the glass surface. The table sets up the rules of the proper procedures.

Solutions resulting out of the following table

In case you suppose the thermal stress will be too high, the glass must be either thermally reinforced or hardened (according to the stress level). SKLENARSTVI NONSTOP s.r.o., takes no guarantee for the risk of spontaneous glass breaking caused by nickel sulphite.

Marking

Each thermally hardened safety glass conforming to the European Standard EN 12150 must be provided with a permanent mark. The marking must contain following information:

- name and commercial mark of the manufacturer
- No. of the European Standard: EN 12150

TABLE OF THE THERMAL STRESS

Reason	Stress	Factors influencing the thermal stress	Advice for the thermal stress reduction
Solar radiation	Frame	Increasing stress depends on: 1.Frame material: - wooden or PVC - dark aluminium frame with thermal refraction - dark heavy metal frame - aluminium frame of light colour with thermal refraction - aluminium of light colour - concrete	It is recommended to insulate the frame from the brickwork
		2.Frame type - solid, light coloured, free of pressure supports, hung, opening - horizontally turnable, sliding - solid or opening by the help of pressure supports	It is recommended to provide covers of the edges in the grooves of the size under or equal to 45 mm.
	Outer shadow caused by the facade itself	Growth in the following case: - vertical projection - horizontal projection - outer jalousie	Keep at least 2 cm of venting area in both sides of the jalousie in the whole length; it can never come into contact of the glass and the jalousie
	Paint on (outer or inner) sheet	Strong stress increase.	Should be precluded.
	Paper or plastic shade (outer or inner)	Strong stress increase.	Should be precluded.
	Inner curtains	Strong stress increase, in case the curtains are non-transparent and non-vented	The space between the glass and curtains must be connected with the air inside the building.
	Objects in contact with the glass	Strong stress increase.	Should be precluded.
Appliances for air-conditioning and heating	Radiators	Stress increase at reduction of the distance between the radiator and glass. The increase with the temperature increase of the radiator.	The radiators and heating pipes shouldn't be located closer to the glass than 20 cm far from it. Temperature of the heating liquid shouldn't exceed 65°C.
	Suction units	Certain stage of stress, if the stream of air is headed directly for the glass. The stress is being increased by the distance lowering between the suction opening and the glass (also in the case they are located in parallel).	The air stream in the room must be always headed in parallel with the glass. The suction opening mustn't be located nearer than 20 cm far from the glass.
	Anti-condensation unit (cooker, movable heating bodies)	Certain stage of the stress	Locate at least 30 cm far from the glass, consider also the output of the appliance and the possible reflection.
	Gas flow-heater	Certain stage of the stress	Shield must be located between the fire and the glass.

CONDITIONS FOR TRANSPORT, STORING AND HANDLING

HANDLING AND TRANSPORT

Safety glass transport is being provided on returnable metal stands. After removing of the safety glass from the transporting stand they are being stored always on the edge vertically to the support and the support is located in a mild inclination. After the safety glass has been handed over on a transporting stand it is necessary to release the securing elements. When handling the glass and during its transport the mutual contact of the glass and strokes on the glass edge must be prevented. Handling and transport of the safety glass is being provided in its vertical position, it must be inset in the way there is no area contact of the adjacent double-glass.

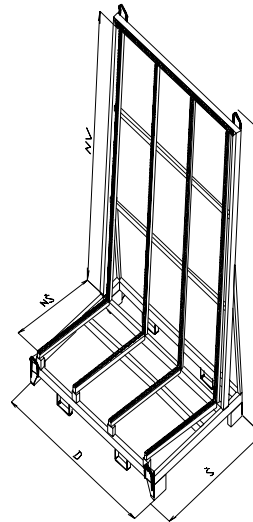
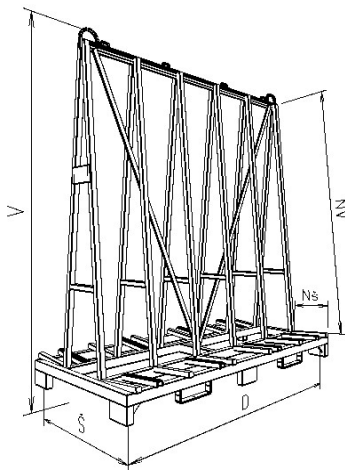

STORING

The glass must be stored in a dry covered area, protected against weathering impacts and direct solar radiation, mechanical damage of the edges, etc. Safety glass is being stored always on the edge and vertically to the base and the base should be in a mild inclination: 10 – 15°.

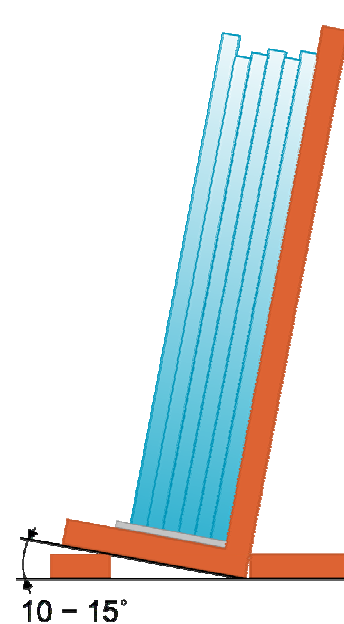

Storing of the safety armoured double-glass in composition

This safety double-glass must be stored individually as pieces in order it doesn't come to a big heat concentration through the used wire inlay inside the armoured glass. As far as this safety double-glass is not installed in the window unit, it mustn't come to a long-term contact with the solar radiation.

INSETTING

It is necessary to insert insets between the particular glass preventing the mutual area contact of the glass. Cork insets or other flexible material is being recommended. The insets must be placed in corners approx. 5 cm far from the glass edge. In case bigger formats are being concerned the insets must be located also in the middle of the glass area. At least two vertically positioned battens must be inserted between the safety glass of various area formats.

The maximum number of the safety double-glass which can be supported in one line after each other comes out from the area size of the biggest double-glass:

up to 1.5 m ²	20 pcs
1,5 – 2.0 m ²	15 pcs
above 2.0 m ²	10 pcs

INSTRUCTIONS FOR GLAZING

BASIC REGULATIONS

Warranty validity depends especially on keeping of the following nine points:

1. Suitable block must be used – support at glazing
2. The glass mustn't be damaged
3. No contact between the glass and metal allowed
4. The side clearances of edges must be kept
5. The works at the installation and maintenance must be provided free of corrosive agent
6. Neither in the groove bottom nor in the sealing materials backwater can be cumulated
7. Maximum pressure round the double-glass shouldn't exceed 20 N/cm.
8. The cement used for the sealing must be and also remain fully waterproof
9. All the materials used at the double-glass installation must be compatible mutually.
The same compatibility must be shown by the double-glass itself and the used frames.

Requirements at safety glass glazing – doors and frames

The safety and protective glass installed in the specially constructed frames must fully fulfil the function when exposed to aggression. The frame must be at least so effective as the glass where the glass is installed. It should fulfil the function regardless the rigidity of the glass itself. The width and depth depends on the type of the glass. At the layered glass the drain is an obligation and it is being recommended also for other types of the safety glass.

CONDITIONS FOR SAFETY GLASS INSTALLATION

For the installation of the safety glass the following conditions must be kept:

- at glazing in the groove-opening construction the set dilatation joints and clearances must be kept
- additional modification of the safety glass dimensions are not allowed
- the safety glass shouldn't be in the direct contact with the steel construction
- the opening construction must be dimensioned in the way in order it doesn't come to deformation after glazing with the safety glass
- the glazing groove must be dry, free of dust, fat or any protuberances
- the glazing groove must be of the dimensions set by the following draft
- the glazing groove must be provided with draining (air) channel
- cementing of the circumference of the safety glass from both sides against the construction groove and glazing battens must be permanently elastic, tight, resistant against moisture protrusion and temperature swinging
- the least allowable distance of the safety glass positioning from the heating bodies is 30 cm against the glass sheet
- the glass must be protected especially during welding, laying of cast asphalt, brickworks
- on the base of the safety glass glazing into a silicone bedding or when gluing the distance supports by silicone it was found out that by the application of an incorrect silicone cement it can come to diffusion of solvents (contained mostly in cheap acetate silicones) and thus to affecting of the consistence of the primary cement – butyl
- for the glass glazing in combination with silicone it is important to use always NEUTRAL SILICONES – recommended by the manufacturer of silicone for these purposes; for request we are able to recommend approved glazing silicones.

- A** safety glass thickness
B carrying and distance supports:
- length 80 up to 100 mm
- width $A + 2$ mm
- thickness 5 mm min.
C sealing thickness 3 mm
D width of the glazing semi-groove $A + 2 \times C$
E depth of the glazing semi-groove:
- 18 mm min. (common glazing)
- 30 mm min. (safety glazing)

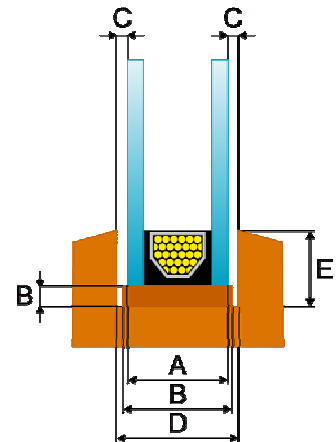

GLASS AFTER INSTALLATION IN THE COSTRUCTION

- All the labels and papers must be removed from the glass immediately after installation as they could cause heat concentration in a small area with subsequent glass refraction.
- In case the safety glass is painted or labelled there it comes to the risk of temperature differences, eventually heat accumulation when the solar radiation there and it can lead to the glass fraction.
- At welding, or grinding in the area of windows an efficient protection of the glass against the pearl effect of welding, against flying sparks, etc. is necessary
- Etching/ disintegration of the glass can be caused by chemicals contained in the construction materials (fresh concrete, plaster, lime, etc.) and cleaners.
- A long-term water action can lead to surface damage. The glass must be cleaned regularly also during the construction if possible.
- Conditions of safety glass installation – see the Glazing methods

BASIC METHODS OF GLAZING

1. Glazing in the full cement bedding:

The groove of the opening construction is being cemented by a permanently elastic cement; the supports will be positioned according to the window type and the safety glass will be inserted; it must be degreased in the circumference. Then the additional cementing will be provided in the whole circumference by permanently elastic cement from both sides. The surplus cement will be removed and the joint circumference will be finished by cement bevelling in the direction of the water flow.

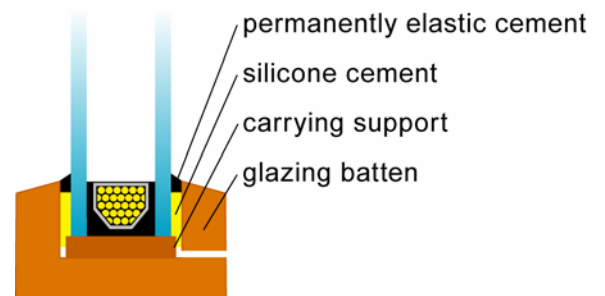

2. Glazing by the help of a sealing tape:

The sealing tape will be glued on in the entire circumference of the groove. The safety glass will be laid on it, supported by the carrying supports and centred by the distance supports. In the circumference of the safety glass the sealing tape will be glued on and the glazing batten will be set on. Then the whole circumference will be closed by the permanently elastic curing cement and will be shaped in the way the edge will be sloped in the direction of the water flow. The groove must be provided by a drain channel (openings with diameter of 8 mm, leading in the exterior).

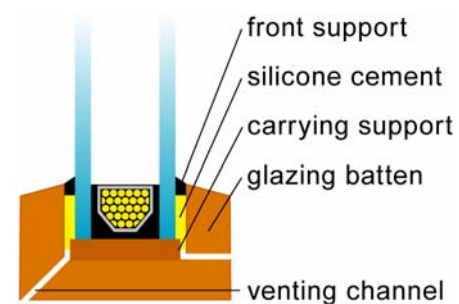

3. Pressure glazing

It is used when safety glass glazing into metal or plastic opening construction is being concerned. The sealing profile resistant to atmospheric impacts has an impact on the function of the circumference sealing and therefore it must be welded or glued in the corners. Regarding the fact that the sealing function is secured by pressure, and it is important that this pressure doesn't exceed 60 N/cm of the circumference.

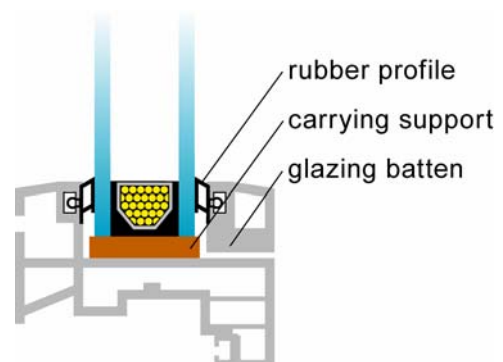

Other glazing methods must always be consulted with the manufacturer!

CONDITIONS FOR SAFETY GLASS INSTALLATION SUPPORTS LOCATION

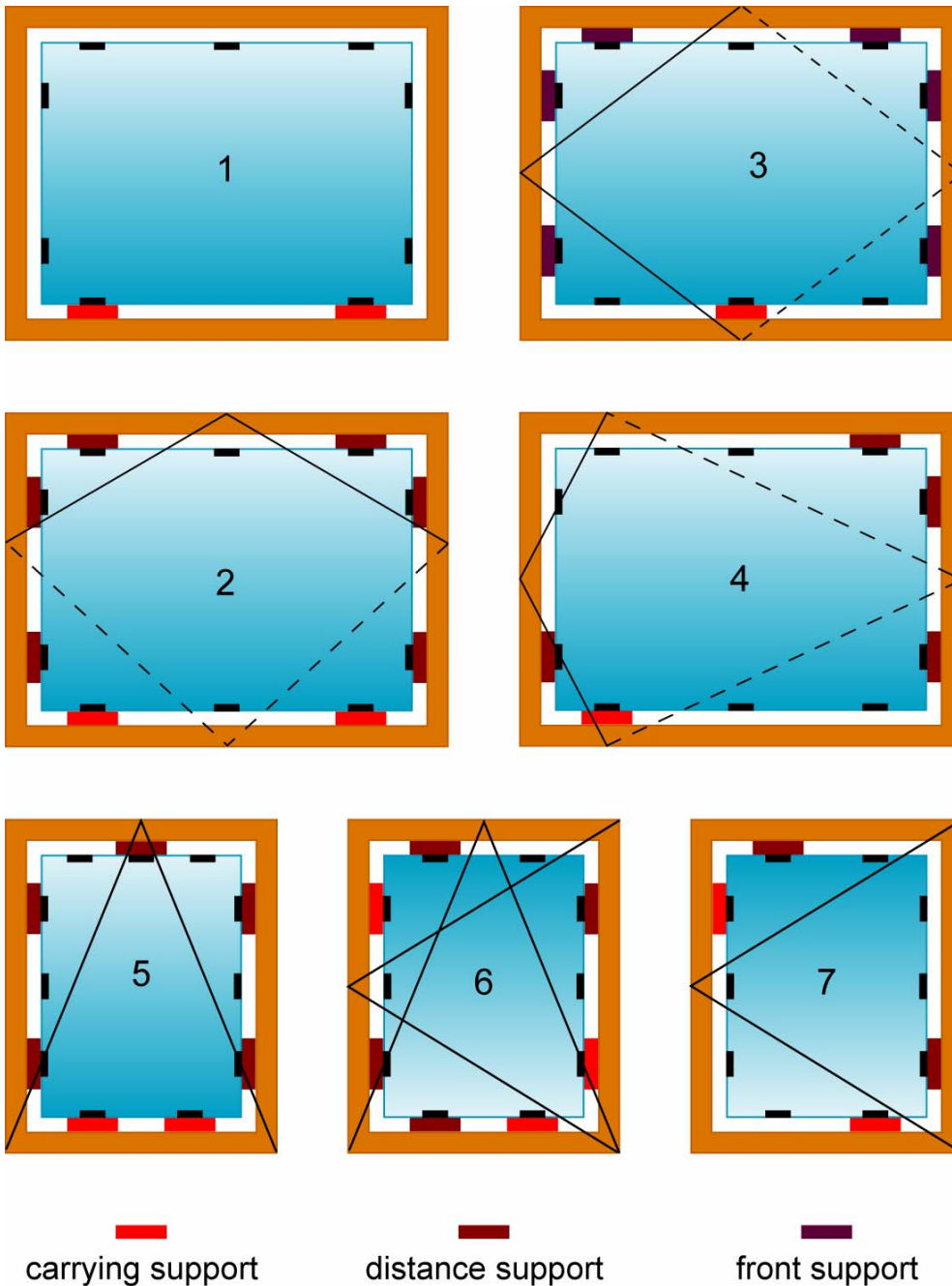

1. solid glazing
2. swing window
3. pivoted window round the vertical axis
4. pivoted window round the vertical axis
5. tilting type window
6. opening and tilting type window
7. opening window

GLASS MAINTENANCE

REMOVAL OF COMMON CONTAMINATION

The glass maintenance can be provided by the help of usual detergents then the glass will be washed by clean water and should be dried out. Fingermarks, spots of fat and cement can be removed by solvents as acetone, ammonia, methylacetone where the contact of solvents with the sealing elements or even their penetration into the glazing groove must be prevented. Abrasive detergents, acid containing agents, chlorine, fluorine or other alkalis shouldn't be used. Beside others it is prohibited to use any assisting tools with hard, spiky and otherwise sharp edges in order to damage the glass surface. It is possible to use also a special wire wool for glass which will clean the glass without scratching the glass.

REMOVAL OF HEAVY CONTAMINATION

In case of strong contamination or in cases where the surplus of concrete, lime, rust, etc. flows on the glass it is recommended to clean it more often in order to prevent the accumulation of deposits. When being contaminated by oil or other substances the cleaning can be provided by a mixture of clean water and cerium oxide in concentration 50 up to 160 g/l. The cleaning itself is to be provided by a light pressure on a wet deerskin. The procedure can be repeated. After having cleaned it the area must be rinsed with clean water.

NOTICE

The above mentioned procedures can be applied on the glass surface without the applied layers or with the layers, which are being marked as hard ones. Cleaning of semi-hard or other layers (paints, printing, foils, etc.) is being provided according to the manufacturers of the layers.

PACKING AND HAND-OVER CONDITIONS

1. Dispatch of safety glass:
 - a. picking up by the customer
 - b. dispatch by the company's vehicle or by trucks of contractual forwarding companies
2. In case of a direct purchase the finished safety glass is being handed over according to the delivery note.
3. The customer will confirm the take-over of the goods on the delivery note, eventually he will record the defects and discrepancies with the order.
The goods will be loaded by the customer, or by the help of workers and mechanisms of the dispatch. Their obligation is to advise the customer of the proper way of loading of the safety glass which is in conformance with the conditions of storing and handling.
4. The customer will be provided with small items for safety glass securing by the employees of the dispatch (cork leads or means for the space filling between the safety glass). The load securing on the vehicle will be provided by the customer.
5. At loading the basic conditions for handling with safety glass must be followed:
 - a. to dispatch just the goods at which the outer cement went through the curing process, the product mustn't be released sooner than after at least 8 hours (winter season), otherwise after 6 hours of curing in the production hall
 - b. the goods must be laid in the vertical position (max. deflection 15°) to the base material not damaging the glass edge, exceptionally in the horizontal position on a soft base material
 - c. cork leads must be inserted between particular safety glass in order to prevent its mutual area contact of the glass
 - d. by the glass loading the responsibility in the full extent is taken-over by the customer; the same is valid for possible damages arisen during transport
6. The dispatch by the company's vehicles or by contractual forwarders of Sklenarstvi NONSTOP is being realized according to the schedule, set up by the responsible worker, with maximum effort of economical usage of the loading capacity. For maintaining of the quality of products and goods the following must be fulfilled:
 - a. the driver checks up the loaded goods with the delivery note continuously and after the loading has been finished the completeness of the load will be confirmed by him in the delivery note, inclusively the stands or packing taken-over
 - b. in case any extraordinary event is arisen during the goods transport the company's management must be informed about it by the driver immediately ; in case it comes to a traffic accident or the load has been damaged it is necessary to secure the investigation of the insured loss
 - c. the goods will be unloaded at the customer, the completeness and integrity will be confirmed on the delivery note and the copy of the delivery note will be handed-over to the responsible worker after his return
 - d. during his return journey he will load vacant packing and stands at the customer's; he will confirm carrying thereof away and the list will be passed over by him to the responsible person after his return into the company
 - e. the damages arisen during the transport will be covered by the Supplier; the supplier will claim them at the driver
 - f. the damages arisen during its unloading or handling at the customer's will be covered by the customer

7. At the safety and constructional glass delivery the supplier will provide the customer with registered transport stands with quick-jigging bars.
8. The stand number and the amount of the quick-jigging bars is stated in the delivery note and together with the delivery it is handed-over to the customer. In case of any doubts the customer must prove when and in which method the complete stands were returned by him.
9. The customer can return the stands to the supplier during the next delivery, in 3 weeks at the latest.
 - a. A longer term for the return can be agreed on for the concrete operation by the customer in advance
 - b. In case the stands are not returned in the set or agreed term; or they are damaged; or destroyed or the stand is lost the purchase price in height of 100%, incl. the V.A.T. will be paid by the customer.
10. Purchase prices of the stands:

– big stand	9.460 Kc
– small stand	7.200 Kc

 - a. In case not the stated amount of the bars is returned; or if they are damaged, the bars will be charged to the customer in the height of the purchase price of the spare bars – 350 Kc per piece.
 - b. The differences, found out at the unloading will be marked out by the customer in the confirmed delivery note and above that, the damaged glass during the transport will be registered into the shipping documentation of the driver.
 - c. All such found, damaged or missing glass will be included in the production on the base of the claiming record as soon as possible and according to the agreement the glass will be delivered together with the claiming protocol in which the receipt of the claimed glass will be confirmed by the customer and then it will be returned to the supplier.
 - d. Each claimed glass will be returned by the buyer with a copy of the claiming protocol back to the supplier in order he can evaluate the given claim.

Worked out by SKLENARSTVÍ NONSTOP s.r.o.

CONTACTS

Invoicing data:

SKLENARSTVI NONSTOP s.r.o.
Kratka 292
763 15 Slusovice
Czech Republic

ID. company's No.: 276 78 270
Tax registration No.: CZ27678270

Free call: 800 12 12 11

Phone: +420 577 158 631
Fax: +420 577 158 632

E-mail: info@sklenarstvinonstop.cz

www. sklenarstvinonstop.cz

www. glassplate.cz

Contact persons:

Company's Director:

Martin Volčík
Cell Phone: +420 777 209 328
info@sklenarstvinonstop.cz

Business Manager:

Petr Vančík
Cell Phone: +420 774 219 328
email@sklenarstvinonstop.cz

Production Manager of Safety Glass:

Pavel Sedláček
Cell Phone: +420 777 209 338
vyroba@sklenarstvinonstop.cz

Production Manager of Glass Cut for Measure, incl. Working:

Petra Kovaříková
Cell Phone: +420 774 823 901
obchod@sklenarstvinonstop.cz

Accounts Manager:

Iveta Kolajová
Cell Phone: +420 774 823 902
uctarna@sklenarstvinonstop.cz

Assistant of the Director:

Michaela Juráková
Cell Phone: +420 774 759 572
asistentka@sklenarstvinonstop.cz



**SKLENÁŘSTVÍ
NONSTOP**

Selling and collecting sites:

Zlín, Svitú area, 22nd building
Zlín, Okružní 4567
Slusovice, Kratka 292
Slusovice, Dostihova 668
Otrokovice, Erbenova 990
Frystak, nám. Míru 48
Vizovice, Masarykovo nám.121
Holešov, Masarykova 650
Vsetín, Okružní 424
Luhačovice, Družstevní 93
Kroměříž, ul. Bilanská 3320
Olomouc, ul. Libusina 598/58
Litovel, ul. Zerotinova 56